

## Description

### Introduction

The PSA is a pressure alarm that provides a contact closure in response to pressure. When the pressure falls outside a preset limit, the PSA activates a relay and an LED on the front panel is illuminated. The unit can be arranged by jumper selection to turn a relay on or off if the pressure drops below or exceeds the set point value.

An optional second (dual) relay can be set to the same specifications or be completely independent.

A jumper selectable fail-safe mode de-energizes the relay when the alarm activates or when power is lost to the unit.

The analog output option provides a 4-20mA or 1-5V signal proportional to the input pressure or alarm set point(s). See Table 1.

**Table 1. Analog Output Selections**

CODE	4-20MA	1-5V	JUMPER SELECT	SWITCH SELECT	SETPOINT 1	SETPOINT 2	PROCESS VARIABLE
AO1	X		X		X		
AO2	X		X			X	
AO3	X		X				X
AO4	X			X	X		
AO5	X			X		X	
AO6	X			X			X
AO7		X	X		X		
AO8		X	X			X	
AO9		X	X				X
AO10		X		X	X		
AO11		X		X		X	
AO12		X		X			X

## Installation

### Introduction

Input and output values for the unit should be checked on site before the unit is placed into service (see Calibration).

Purge the mounting blocks and air lines of any debris before installing the PSA. This is done by inserting a small diameter, blunt tip probe into the fittings and unseating the ball check valves for a few seconds while pressurized.

### Mechanical Installation

The PSA comes as a basic rail-mount unit with options for location of pneumatic fittings, test jacks and relay contacts. See table 2 and figure 1. Case widths are shown in tables 3 and 4.

**Table 2. Access Designation**

POWER SUPPLY & CONTACT TERMINAL LOCATION	PNEUMATIC INPUT LOCATION	ACCESS DESIGNATION
Front	Bottom	-FA1
Front	Rear	-FA2
Front	(no mounting block)	-FA7
Rear	Rear	-RA1
Rear	Bottom	-RA2
Rear	(no mounting block)	-RA7

## Electrical Connections

The terminals are compression screw sockets that accept 22 to 14 AWG hookup wire with the insulation stripped back 0.5 inches from the end. Observe proper polarity as shown on the label when making electrical connections.

Terminal designations for 24Vdc units are shown in Table 3. Terminal designations for 117Vac units are shown in Table 4.

Dc powered units require an external supply voltage for the analog output circuit. The current requirement at 24Vdc, nominal, is 50mA. The DPS240 power supply offered by Moore Industries provides the correct output current and also comes in a DIN-style housing.

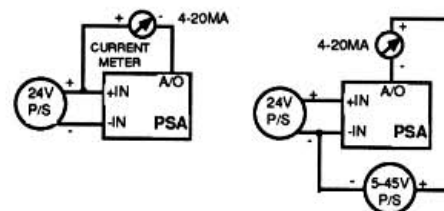

**Figure A. DC Powered, Current Output Hook-up Diagrams**

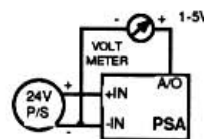

**Figure B. DC Powered, Voltage Output Hook-up Diagram**

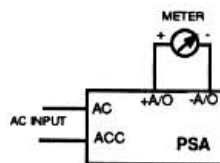

**Figure C. AC Powered, Current/Voltage Output Hook-up Diagram**

**Important Note:** This document is complete as of the printing date; however, subsequent product changes may be reflected in companion documents.

# Specifications

<p><b>Characteristics</b></p> <p><b>Front Panel Adjustments</b> <b>Trip Points:</b> Multiturn adjustment over a range of 0-100% of span. <b>Panel Connections:</b> Power supply Relay contacts (NO/NC standard) <b>Internal Selection (Jumpers):</b> Alarm actuates on increase or decrease in pressure. Alarm condition energizes or de-energizes relay.</p>	<p><b>Line Voltage Effect:</b> Negligible <b>Deadband:</b> 1% of span nominal fixed, standard <b>Analog Output:</b> <b>Ac Powered Unit</b> Isolate 4-20mA @ 24 volts nominal Maximum loop resistance is 953 ohms. <b>Dc Powered Unit</b> 4-20mA (4-45 Volts excitation required) <b>Ac or Dc Powered Unit</b> 1-5 Vdc</p> <p><b>Weight</b> Approximately 10 ounces (283.4 grams)</p>	<p><b>Solid State Relays (Dc):</b> <b>SDH1</b> Solid state dc relay, high alarm, turns relay ON <b>SDH2</b> Turns relay OFF <b>SDL1</b> Solid state dc relay, low alarm, turns relay ON <b>SDL2</b> Turns relay OFF</p> <p><b>Power</b> <b>24DC</b> 24Vdc, ±10% <b>117AC</b> 117Vac, ±10% <b>220AC</b> 220Vac, ±10% <b>240AC</b> 240Vac, ±10%</p> <p><b>Options</b> <b>-AD</b> Adjustable deadband, 1-20%* <b>-AO</b> Analog output. See table 1. <b>-P</b> Single-turn knob set-point potentiometer <b>-RTB</b> Removable terminal block <b>-SR</b> Solid state relays, rated 3A @ 60Vdc or 240Vac <b>-TJ</b> Pneumatic test jack <b>-TT</b> Precision 10-turn lockable dial with vernier scale**</p>
<p><b>Performance</b> <b>Mechanical Relay Contact Rating:</b> 6A, 28Vdc (resistive load) 6A, 300Vac (resistive load) 1/8HP, 120Vac 1/8HP, 240Vac <b>Calibration Capability:</b> 20-turn trim pot ±0.5% of full scale Single-turn potentiometer ±3% of full scale 10-turn vernier potentiometer ±1% of full scale Analog output version ±0.5% of full scale <b>Repeatability:</b> 0.2% of span <b>Ambient Temperature Effects:</b> 0 to 50°C (32-122°F) Span 1.5% of full scale Zero 2.0% of full scale <b>Operating Temperature Range:</b> -18 to 82°C (0-180°F) <b>Proof Pressure:</b> 150% of range <b>Wetted Parts:</b> Aluminum port, chrome steel check ball, Buna-N o-ring and ceramic transducer.</p>	<p><b>Ordering Specifications</b></p> <p><b>Unit</b> <b>PSA</b></p> <p><b>Input</b> <b>0-5PSI</b> <b>0-15PSI</b> <b>0-30PSI</b> <b>0-50PSI</b> <b>0-100PSI</b></p> <p><b>Output</b> <b>Mechanical Relays:</b> <b>MH1</b> Mechanical SPDT relay, high alarm, turns relay ON <b>MH2</b> Turns relay OFF <b>ML1</b> Mechanical SPDT relay, low alarm, turns relay ON <b>ML2</b> Turns relay OFF</p> <p><b>Solid State Relays (Ac):</b> <b>SAH1</b> Solid state ac relay, high alarm, turns relay ON <b>SAH2</b> Turns relay OFF <b>SAL1</b> Solid state ac relay, low alarm, turns relay ON <b>SAL2</b> Turns relay OFF</p>	<p><b>Access Designations</b> All units are configured according to the Access Designations shown in table 2. These locate electrical supply, relay connections, and pneumatic connections. When mechanical and solid state relays are combined in one unit, the mechanical relay is always relay 1.</p> <p><b>Housings</b> <b>DIN</b> Rail-Mount housing, snaps onto a standard "G" DIN rail for high density installation. Units with -FA1, -FA2, -RA1, -RA2 access designation have a rail-mounting pneumatic mounting block. -FA7, and -RA7, units are for replacement units only.</p>

**Model number description:** Unit Type / Input / Output / Power / Options, Access Designations [Housing]

\*Applies to both relays  
\*\*Not available on ac units

**Table 3** PSA-DIN 24Vdc Installation Information

Output	Options					Case Width	Input	Relay #1	Relay #2
One Mechanical Relay	None		-P	(-TJ) -TJ (-TJ)		A B B B	+IN -IN	NO COM NC 	
		-AO -AO -AO	-P	(-TJ) (-TJ) (-TJ)	-TT	B B C	+IN -IN AO	NO COM NC 	
Two Mechanical Relays	None		-P -P	-TJ -TJ (-TJ)		B B C C D	+IN -IN	NO COM NC 	NO COM NC 
		-AO -AO -AO	-P	(-TJ) (-TJ) (-TJ)	-TT	C C D	+IN -IN AO	NO COM NC 	NO COM NC 
One Solid-state Relay	None		-P	(-TJ) -TJ (-TJ)		A B B B	+IN -IN	+ - 	
		-AO -AO -AO	-P	(-TJ) (-TJ) (-TJ)	-TT	B B C	+IN -IN AO	+ - 	
Two Solid-state Relays	None		-P	(-TJ) (-TJ)	-TT	B B D	+IN -IN	+ - 	+ - 
		-AO -AO -AO -AO -AO	-P -P	-TJ -TJ (-TJ)	-TT	B B C C D	+IN -IN AO	+ - 	+ - 
One Mechanical and One Solid-state Relay	None					B	+IN -IN	NO COM NC 	+ - 
		-AO -AO -AO -AO -AO	-P -P	(-TJ) (-TJ) -TJ	-TT	B C D B C	+IN -IN AO	NO COM NC 	+ - 

**Table 3a** Key to Abbreviations for PSA-DIN

-AO	Analog Output
-P	Single-turn knob setpoint potentiometer
-TJ *	Test jack
-TT	Precision ten-turn lockable dial with vernier scale
A	1.2 in. case width
B	1.8 in. case width
C	2.4 in. case width
D	3.2 in. case width

\* Test jack (-TJ) option is shown in parentheses to indicate that the unit may or may not have this option.

**Table 4** PSA-DIN 117Vac Installation Information

Output	Options				Case Width	Input	Relay #1	Relay #2
One Mechanical Relay				-TJ	C	AC ACC	NO COM NC	
	-AO	-AO	-P	(-TJ) (-TJ)	C C	AC ACC +AO -AO	NO COM NC	
Two Mechanical	None			(-TJ)	C C	AC ACC	NO COM NC	NO COM NC
		-AO			C	AC ACC +AO -AO	NO COM NC	NO COM NC
One Solid-state Relay				-TJ	C	AC ACC		
	-AO	-AO	-P	(-TJ) (-TJ)	C C	AC ACC +AO -AO		
Two Solid-state Relays			-P	(-TJ) (-TJ)	C C	AC ACC		
	-AO	-AO	-P	-TJ (-TJ)	C C C	AC ACC +AO-AO		
One Mechanical and One Solid-state			-P	-TJ	C	AC ACC	NO COM NC	
	-AO				C	AC ACC +AO -AO	NO COM NC	

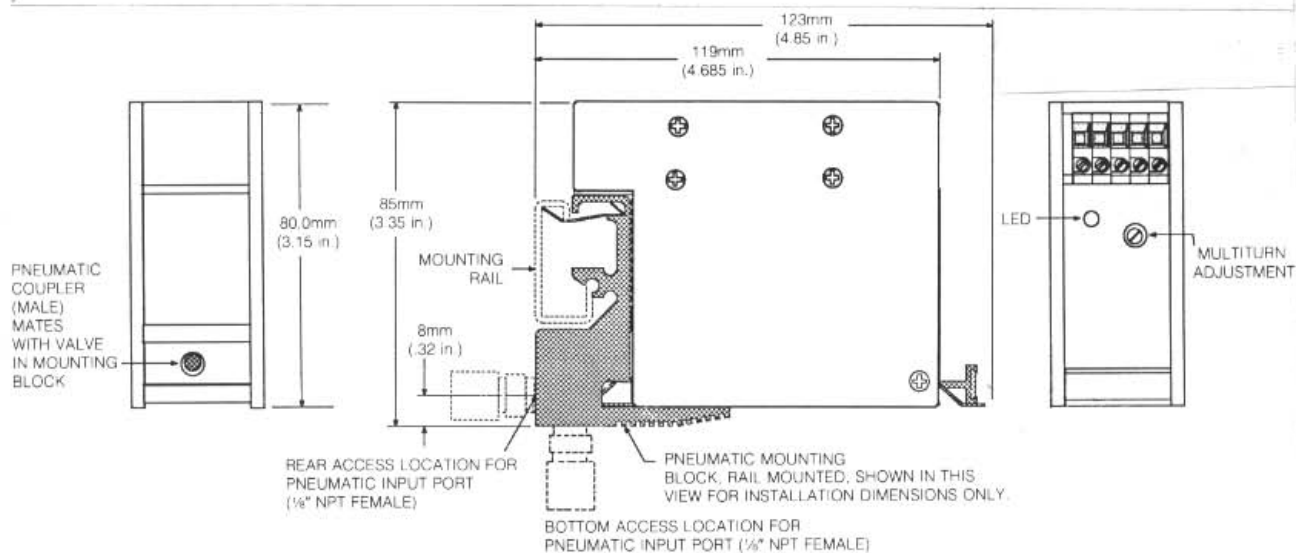

**Figure 1.** PSA Installation Dimensions

## Calibration

### Introduction

This section provides the necessary information to calibrate the unit. Each unit is adjusted and checked at the factory for proper performance before shipping.

The ZERO (R16) and SPAN (R15) potentiometers internal to the unit on PC1, usually require 20 turns of the shaft to move the wiper from one end of its range to the other. The pot is equipped with a slip clutch at either end of its travel to prevent damage if turned beyond the wiper stop.

A slight change in torque to turn the shaft is noticed when the clutch is slipping. If this change cannot be sensed, either end of the pot can be reached by 20 turns of the shaft in the desired direction.

Turning the control shaft clockwise increases the quantity or makes it more positive. Counterclockwise decreases the quantity or makes it more negative.

### Jumper Selection

On the PSA as in any alarm, there are two conditions that must be met: alarm condition and relay condition.

The alarm condition decides whether the unit will alarm when the process variable reaches or exceeds a trip point (high alarm) or when the process variable reaches or goes lower than a trip point (low alarm). The alarm condition is selected with jumpers J9-J12. See figure 8.

#### PC1 - Relay KA

For a high alarm, jumpers J10 and J12 are installed.  
For a low alarm, jumpers J9 and J11 are installed.

#### PC2 - Relay KB

For a high alarm, jumpers J201 and J202 are installed.  
For a low alarm, jumpers J203 and J204 are installed.

A relay condition decides whether the relays are energized (ON) or de-energized (OFF) in the alarm condition. Whether the relays are solid-state or mechanical they are numbered according to whether they turn ON or OFF. Refer to Ordering Specifications on page 3. A "1" indicates the relay turns ON (e.g.,

MH1, SAL1), a "2" indicates the relay turns OFF (e.g., MH2, SAH2). The relay condition is decided by jumpers J1-J4. See figure 6.

#### PC1 - Relay KA - Energize in Alarm ("1" or ON)

Install jumpers J2 and J4

#### PC1 - Relay KA - De-energize in Alarm, Fallsafe ("2" or OFF)

Install jumpers J1 and J3

#### PC2 - Relay KB - Energize in Alarm ("1" or ON)

Install jumpers J6 and J8

#### PC2 - Relay KB - De-energize in Alarm, Fall-safe ("2" or OFF)

Install jumpers J5 and J7

## Adjusting and Calibrating

### Base Unit Adjustment

1. a. Turn set point A potentiometer fully counterclockwise.  
b. Apply 0% pressure.  
c. Adjust base unit ZERO potentiometer (R17) for zero volts between U3-8 and U4-1.
2. a. Turn set point A potentiometer fully clockwise.  
b. Apply full scale pressure.  
c. Adjust base unit SPAN potentiometer (R15) for zero volts between U3-8 and U4-1.
3. Repeat steps 1 and 2 until no readjustment is needed.

Table 5. Test Equipment and Tools

Equipment or Tool	Characteristic	Purpose
Suitable power source	24 Vdc, ±10%	
Screwdriver (blade)	Blade no wider than 2.54 mm (0.1")	To adjust front panel ZERO and SPAN.
Adjustable instrument air supply	0 to Full Scale pressure	To simulate pressure input.
Dc voltmeter temperature	Must be accurate to ±0.05%, or better Ambient Temp. = 20°C to 35°C (68°F - 94°F)	To measure the signals to avoid causing errors in process data.
Phono tip probes (2)	Must have 2.03 mm (.080") dia. tips, 12.7 mm (.50") long handles 6.5 mm (.25") dia.	Easy monitoring of output signals.
163-202-00 Pneumatic test coupler	MII test coupler for PSA's with optional pneumatic test jack	Easy monitoring of input signals.

### Analog Output Adjustment

1. Select set point A output.
2. Turn set point A potentiometer fully counterclockwise.
3. Adjust analog output ZERO potentiometer (R210) for 1 volt or 4 mA (whichever is appropriate).
4. Turn set point A potentiometer fully clockwise.
5. Adjust analog output SPAN potentiometer (R209) for 5 volts or 20mA (as appropriate).  
Repeat steps 2-5 as needed.

## Theory of Operation

This section briefly describes how the PSA operates. A simplified block diagram of the unit is provided to help understand the circuit description. See Figure 2. A detailed schematic is found in Figure 5 and assembly drawings are included in Figures 6-8.

The solid-state pressure transducer is excited by a constant current circuit, which maintains a constant voltage across a fixed resistance in series with the transducer, see Figure 3.

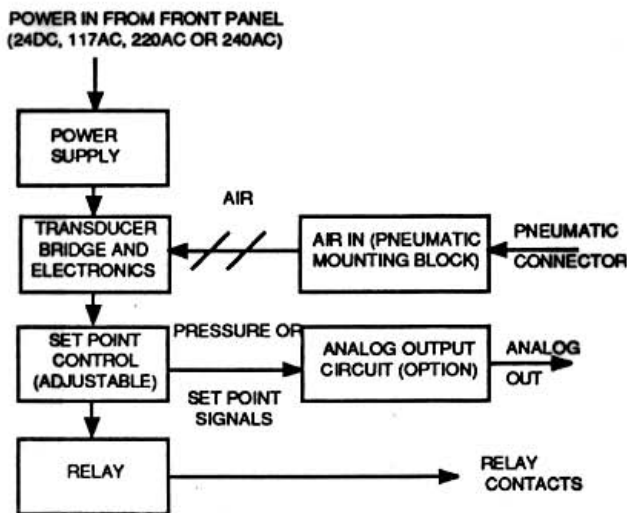

Figure 2. PSA Block Diagram

The set point voltage level is derived from the voltage developed across the sense resistor.

The transducer bridge output is amplified through a differential amplifier to produce the "pressure signal". Its span and zero are adjusted to match the range of the set point voltage, typically .5 to 2.5 volts. Figure 4 shows the PSA Ratiometric Operation.

The pressure and voltage signals are then fed into

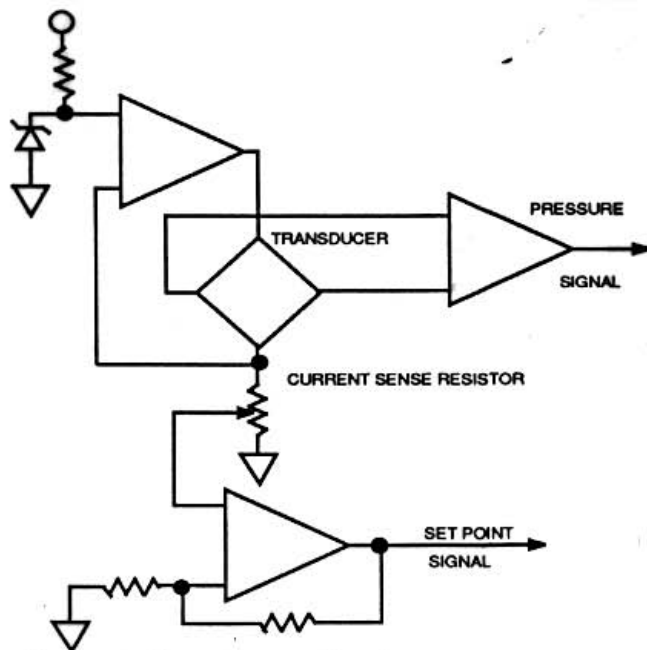

Figure 3. Solid-state Pressure Transducer

two comparators in series. The polarity sense of each comparator is jumper selectable. The first comparator has single-sided hysteresis. The second drives the relay. This allows Hi/Lo and fail-safe operation with single-sided hysteresis.

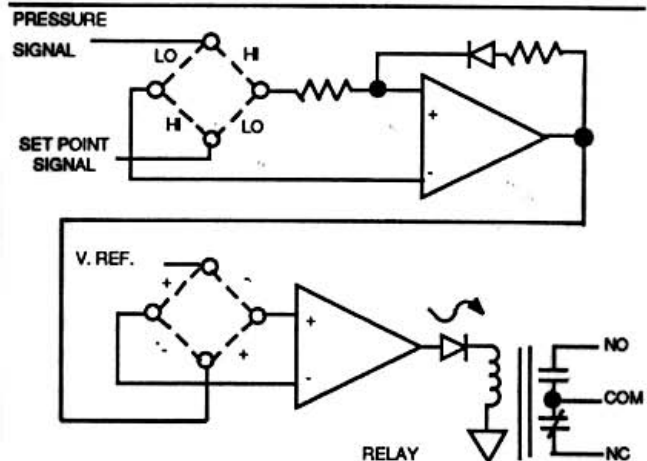

Figure 4. The PSA Ratiometric Operation.

### Analog Output Options (DIN version only)

The voltage output option is comprised of a non-inverting amplifier with a nominal gain of 2 (adjustable  $\pm 8\%$ ). It also has an offset adjustment. It amplifies either the set point voltage or the pressure signal. Its span and zero are adjusted for 1-5 volts output.

The current output option has a similar input configuration and adjustment range except its output has an open drain, N-Channel MOSFET. A resistor between its source and ground provides the feedback voltage to the amplifier's inverting input. Span and zero are adjusted for 4-20 mA out. Dc powered units require a user supplied power for analog output circuit. It may be anywhere between 3 and 45 volts.

### AC Powered Units (DIN version only)

A conversion between AC and 24Vdc is accomplished through a split primary transformer with a 4-diode bridge rectifier on the output.

The primaries are connected in parallel for 117Vac operation, and are connected in series for 220 volt operation.

## Troubleshooting

If the relay does not work at all, check to see if +15 volts and 24 volts are present. If these voltages are present, apply some intermediate pressure (between 0-100%). Use the SET POINT potentiometer to check for active signals in the circuit.

Next, check to see if the output of the relay driver circuits (U1, pin 1 or 7) can be forced high by turning the SET POINT potentiometer from one extreme to the other. If the output goes high  $\geq 15.7$  volts) then either the relay or LED circuit is open. If the output does not go high, check to see if the differential inputs change respective polarity.

If the differential inputs do not change polarity, check that the pressure signal is active (U3, pin 10). An active condition exists when 0% pressure is  $\approx 0.5$  volts and 100% pressure is  $\approx 2.5$  volts.

If the pressure signal is active, then there is a problem with the comparator(s) or there may be a short in the relay.

If the pressure signal is not active, check the excitation current (U3, pin 2) for a voltage  $\approx 1.23$  volts. U3, pin 3 should have at least 6 volts. If not, there may be a short or open in the constant current path of the reference diode and it may not have 1.23 voltage drop across it. Also, U3 may be defective.

**Table 6. Jumper Location Diagnosis**

Symptom	Problem	Solution
Deadband on wrong side, but alarm sense (i.e. relay activates on under/over pressure) is correct.	Hi/Lo and fail-safe jumpers are reversed.	Change jumpers
Deadband on wrong side and alarm is reversed.	Hi/Lo jumpers are reversed.	Change jumpers
Deadband on right side but alarm sense is reversed.	Fail-safe jumpers are reversed.	Change jumpers

**Table 7. Additional Troubleshooting**

Symptom	Problem	Solution
The transducer has excitation and output but pressure signal is not active.	The differential amplifier is probably defective.	Refer to return factory repair procedure.
Analog output can not be calibrated according to procedure, and all of the inputs are correct	U202 may be defective. On current output types, Q201 may be defective or the excitation voltage (3-45 V) may be absent or the output could be shorted.	
AC power supply does not work.	Check for proper input levels. Check for proper output levels. Check diodes and caps for shorts/opens.	



141-401-00D

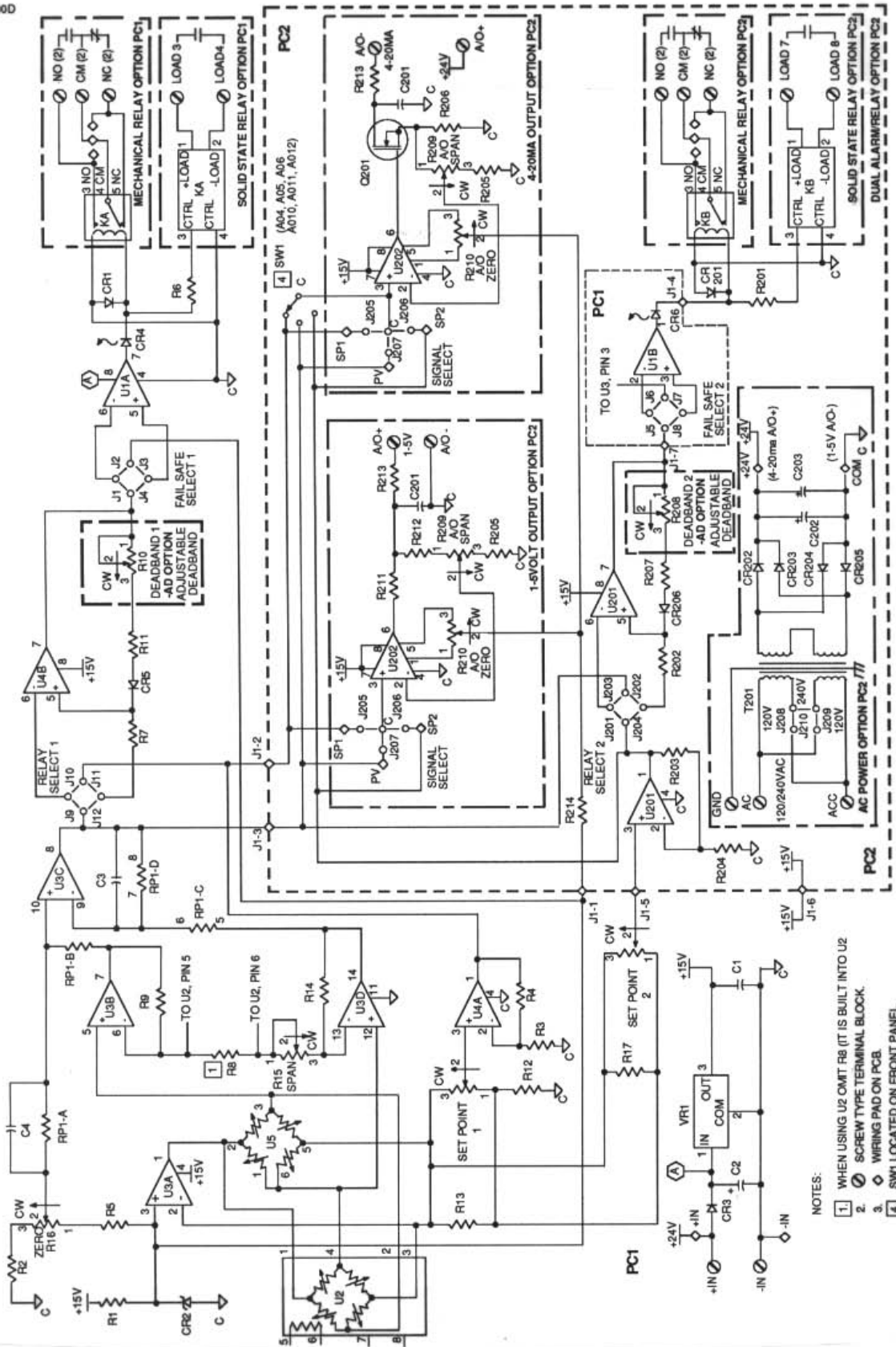

- NOTES:
- 1. WHEN USING U2 OMIT R8 (IT IS BUILT INTO U2)
  - 2. SCREW TYPE TERMINAL BLOCK.
  - 3. WIRING PAD ON PCB.
  - 4. SW1 LOCATED ON FRONT PANEL.

Figure 5. PSA Schematic

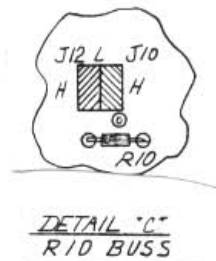
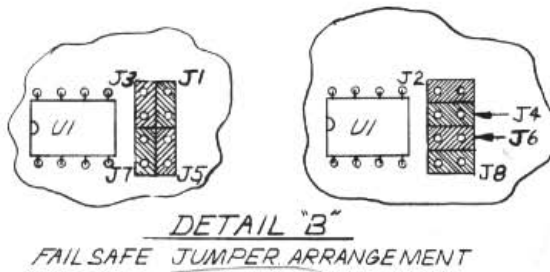
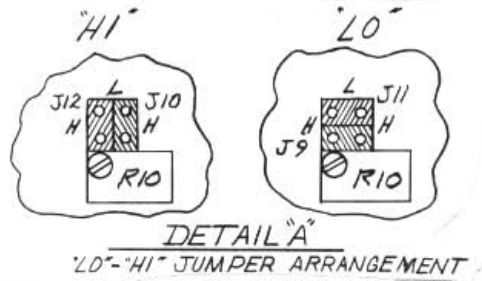
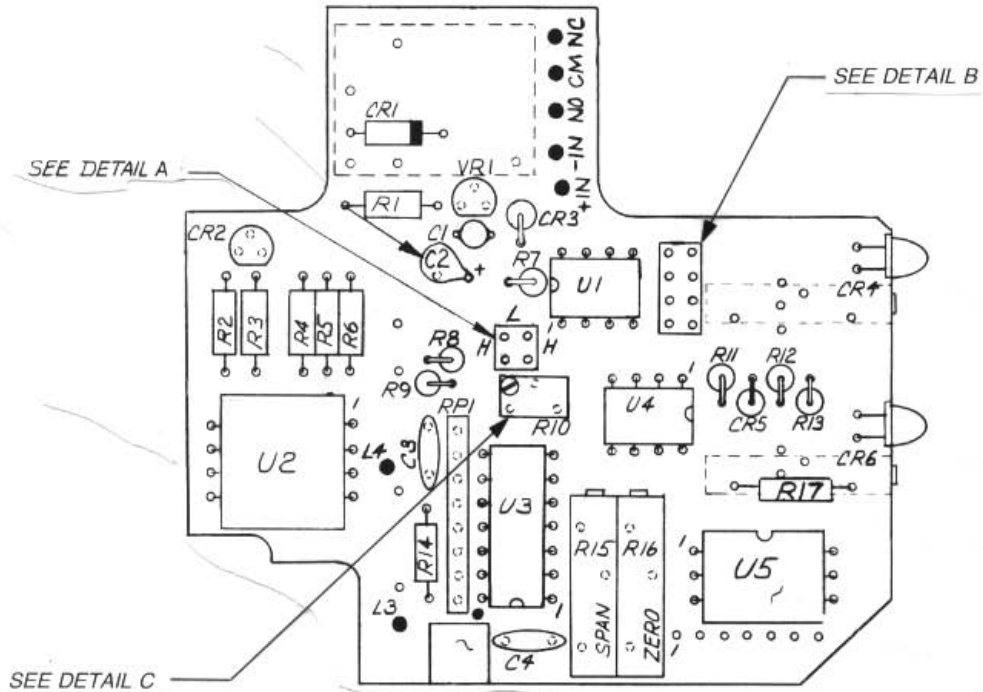

Figure 6, PSA Assembly PC1

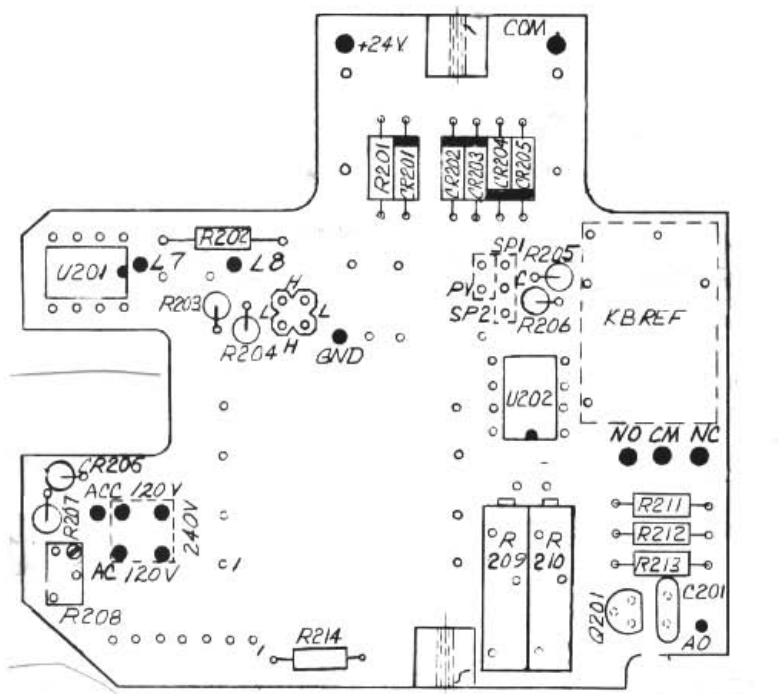

Figure 7. PSA Assembly PC2

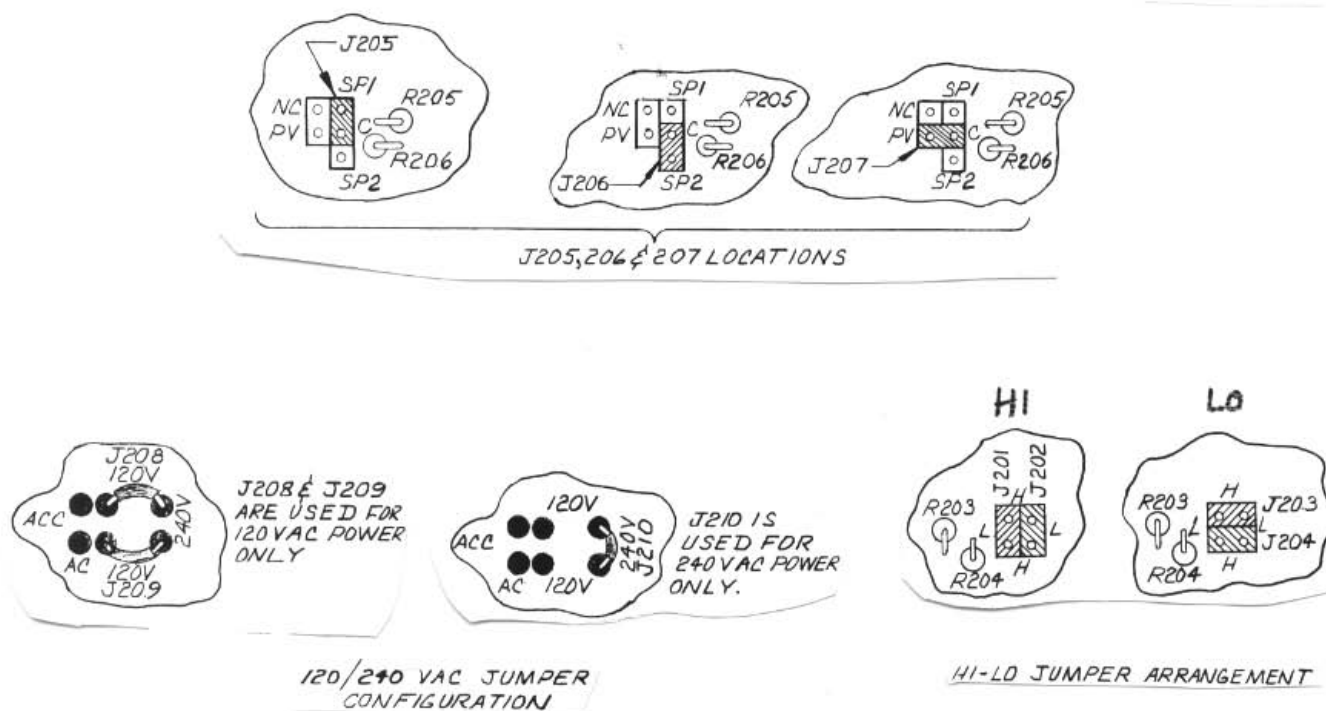

Figure 8. PSA Jumper Locations PC2

## RETURN PROCEDURES

### To return equipment to Moore Industries for repair, follow these four steps:

1. Call Moore Industries and request a Returned Material Authorization (RMA) number.

#### Warranty Repair –

If you are unsure if your unit is still under warranty, we can use the unit's serial number to verify the warranty status for you over the phone. Be sure to include the RMA number on all documentation.

#### Non-Warranty Repair –

If your unit is out of warranty, be prepared to give us a Purchase Order number when you call. In most cases, we will be able to quote you the repair costs at that time. The repair price you are quoted will be a "Not To Exceed" price, which means that the actual repair costs may be less than the quote. Be sure to include the RMA number on all documentation.

2. Provide us with the following documentation:
  - a) A note listing the symptoms that indicate the unit needs repair
  - b) Complete shipping information for return of the equipment after repair
  - c) The name and phone number of the person to contact if questions arise at the factory
3. Use sufficient packing material and carefully pack the equipment in a sturdy shipping container.
4. Ship the equipment to the Moore Industries location nearest you.

The returned equipment will be inspected and tested at the factory. A Moore Industries representative will contact the person designated on your documentation if more information is needed. The repaired equipment, or its replacement, will be returned to you in accordance with the shipping instructions furnished in your documentation.

#### WARRANTY DISCLAIMER

THE COMPANY MAKES NO EXPRESS, IMPLIED OR STATUTORY WARRANTIES (INCLUDING ANY WARRANTY OF MERCHANTABILITY OR OF FITNESS FOR A PARTICULAR PURPOSE) WITH RESPECT TO ANY GOODS OR SERVICES SOLD BY THE COMPANY. THE COMPANY DISCLAIMS ALL WARRANTIES ARISING FROM ANY COURSE OF DEALING OR TRADE USAGE, AND ANY BUYER OF GOODS OR SERVICES FROM THE COMPANY ACKNOWLEDGES THAT THERE ARE NO WARRANTIES IMPLIED BY CUSTOM OR USAGE IN THE TRADE OF THE BUYER AND OF THE COMPANY, AND THAT ANY PRIOR DEALINGS OF THE BUYER WITH THE COMPANY DO NOT IMPLY THAT THE COMPANY WARRANTS THE GOODS OR SERVICES IN ANY WAY.

ANY BUYER OF GOODS OR SERVICES FROM THE COMPANY AGREES WITH THE COMPANY THAT THE SOLE AND EXCLUSIVE REMEDIES FOR BREACH OF ANY WARRANTY CONCERNING THE GOODS OR SERVICES SHALL BE FOR THE COMPANY, AT ITS OPTION, TO REPAIR OR REPLACE THE GOODS OR SERVICES OR REFUND THE PURCHASE PRICE. THE COMPANY SHALL IN NO EVENT BE LIABLE FOR ANY CONSEQUENTIAL OR INCIDENTAL DAMAGES EVEN IF THE COMPANY FAILS IN ANY ATTEMPT TO REMEDY DEFECTS IN THE GOODS OR SERVICES, BUT IN SUCH CASE THE BUYER SHALL BE ENTITLED TO NO MORE THAN A REFUND OF ALL MONIES PAID TO THE COMPANY BY THE BUYER FOR PURCHASE OF THE GOODS OR SERVICES.

ANY CAUSE OF ACTION FOR BREACH OF ANY WARRANTY BY THE COMPANY SHALL BE BARRED UNLESS THE COMPANY RECEIVES FROM THE BUYER A WRITTEN NOTICE OF THE ALLEGED DEFECT OR BREACH WITHIN TEN DAYS FROM THE EARLIEST DATE ON WHICH THE BUYER COULD REASONABLY HAVE DISCOVERED THE ALLEGED DEFECT OR BREACH, AND NO ACTION FOR THE BREACH OF ANY WARRANTY SHALL BE COMMENCED BY THE BUYER ANY LATER THAN TWELVE MONTHS FROM THE EARLIEST DATE ON WHICH THE BUYER COULD REASONABLY HAVE DISCOVERED THE ALLEGED DEFECT OR BREACH.

#### RETURN POLICY

For a period of thirty-six (36) months from the date of shipment, and under normal conditions of use and service, Moore Industries ("The Company") will at its option replace, repair or refund the purchase price for any of its manufactured products found, upon return to the Company (transportation charges prepaid and otherwise in accordance with the return procedures established by The Company), to be defective in material or workmanship. This policy extends to the original Buyer only and not to Buyer's customers or the users of Buyer's products, unless Buyer is an engineering contractor in which case the policy shall extend to Buyer's immediate customer only. This policy shall not apply if the product has been subject to alteration, misuse, accident, neglect or improper application, installation, or operation. THE COMPANY SHALL IN NO EVENT BE LIABLE FOR ANY INCIDENTAL OR CONSEQUENTIAL DAMAGES.



**WORLDWIDE • www.miinet.com**

United States • info@miinet.com Tel: (818) 894-7111 • FAX: (818) 891-2816	Belgium • info@mooreind.be Tel: 03/448.10.18 • FAX: 03/440.17.97	China • sales@mooreind.sh.cn Tel: 86-21-62491499 • FAX: 86-21-62490635
Australia • sales@mooreind.com.au Tel: (02) 8536-7200 • FAX: (02) 9525-7296	The Netherlands • sales@mooreind.nl Tel: (0)344-617971 • FAX: (0)344-615920	United Kingdom • sales@mooreind.com Tel: 01293 514488 • FAX: 01293 536852